

Model 1215

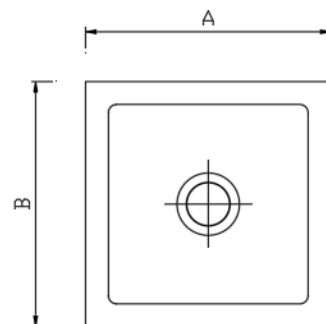

Model 1116

1215

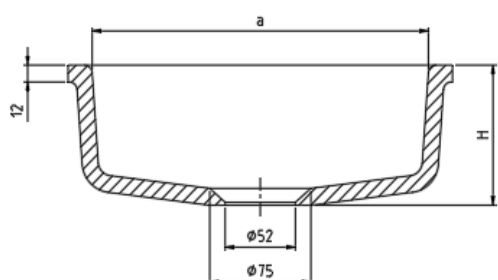

1116

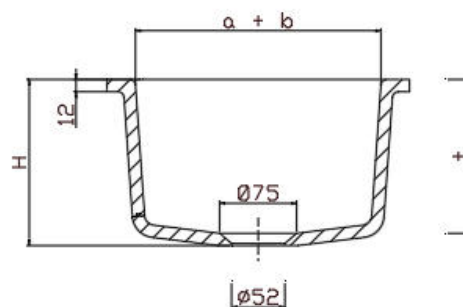
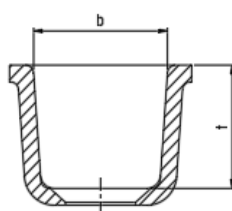

Dimensions in mm						Weight approx. kg	Model-No.
exterior approx.			interior approx.				
A	B	H	a	b	t		
285	130	100	250	100	88	3	1215
295	295	165	240	240	150	6	1116

Cutout dimension, glazed	Outlet form	Model-No.
244x90 mm	0680	1215
220x220 mm	0680	1116

Material: Chem.-techn. stoneware according to EN 14879-6, chart 5

Execution: The exterior of the sinks is unglazed and the edge is cut to size.

Tolerances: Material depending tolerances +/- 1,5 %