

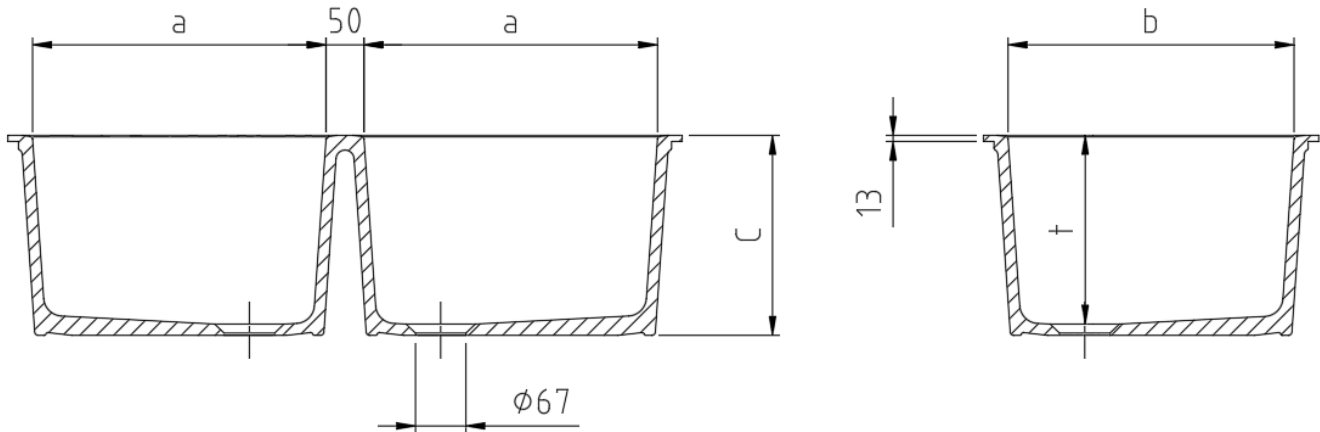

Model 2940

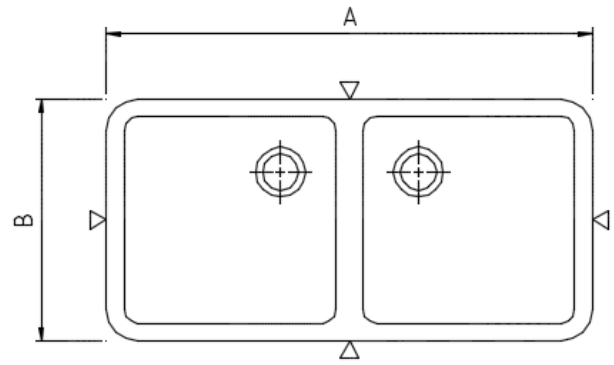

Dimensions in mm						Weight approx. kg	Model-No.
exterior approx.			interior approx.				
A	B	C	a	b	t		
895	445	265	390	380	250	38	2940

Cutout dimension, glazed	Outlet form	Model-No.
901x451 mm	0580	2940

Material: Chem.-techn. stoneware according to EN 14879-6, chart 5

Execution: The exterior of the sinks is unglazed and the edge is cut to size.

Tolerances: Material depending tolerances +/- 1,5 %