

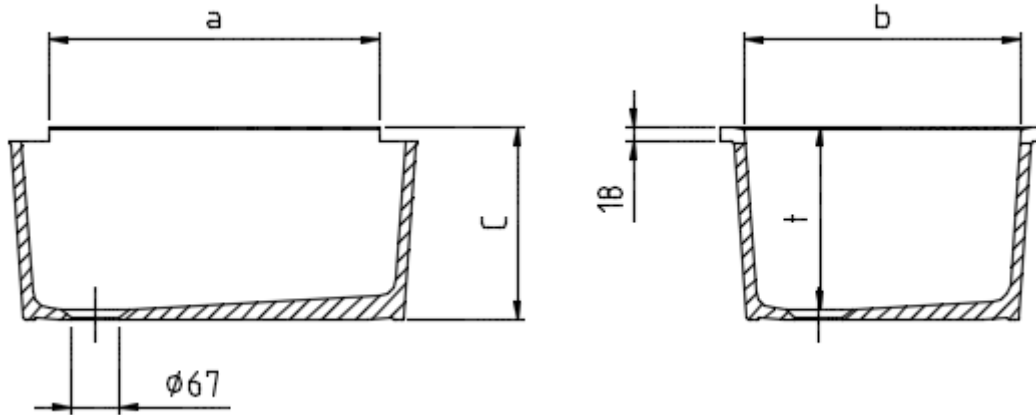

Model 2701

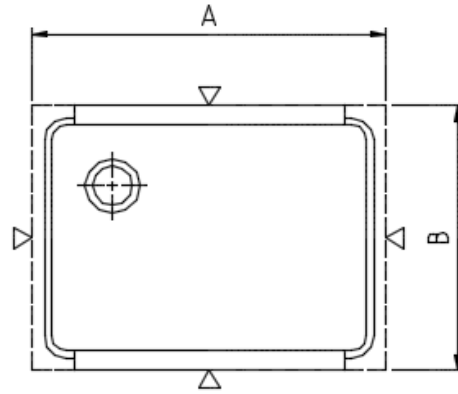

Dimensions in mm						Weight approx. kg	Model-No. with edge recessing		
exterior approx.			interior approx.				both sides	left side	right side
A	B	C	a	b	t				
445	445	265	305	380	250	20	2601		
445	445	265	375	380	250	21		2603	2604
595	445	265	455	380	250	23	2701		
595	445	265	525	380	250	24		2703	2704

Cutout dimension, in combination with drain top/s 9205	Outlet form	Model-No.
1205x455 mm	0575	2601
830x455 mm	0575	2603/2604
1355x455 mm	0575	2701
980x455 mm	0575	2703/2704

Material: Chem.-techn. stoneware according to EN 14879-6, chart 5

Execution: The exterior of the sinks is unglazed and the edge is cut to size.

Tolerances: Material depending tolerances +/- 1,5 %