

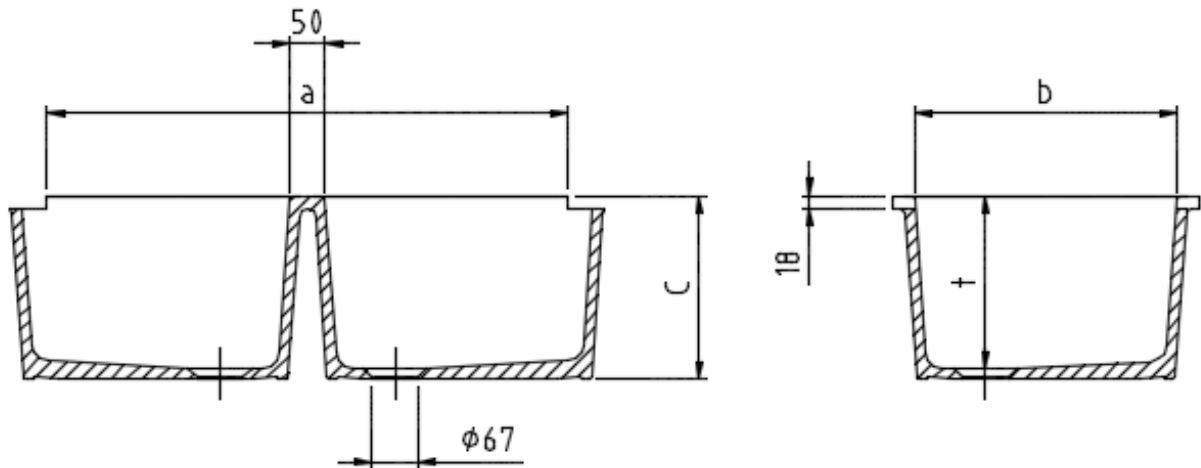

Model 2901

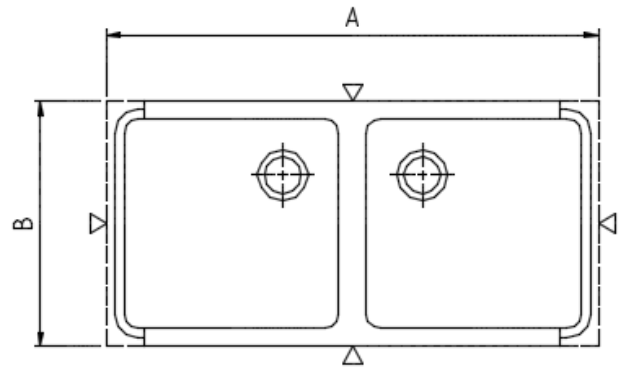

Dimensions in mm						Weight approx. kg	Model-No. with edge recessing		
exterior approx.			interior approx.				both sides	left	right
A	B	C	a	b	t				
895	445	265	755	380	250	36	2901		
895	445	265	825	380	250	37		2903	2904

Cutout dimension, in combination with drain top/s 9205	Outlet form	Model-No.
1655x455 mm	0580	2901
1275x455 mm	0580	2903/2904

Material: Chem.-techn. stoneware according to EN 14879-6, chart 5

Execution: The exterior of the sinks is unglazed and the edge is cut to size.

Tolerances: Material depending tolerances +/- 1,5 %